



# USB-RS232-TTL-STICK

Hardware-Description

2010 Oktober

# INDEX

<b><u>1. Introduction</u></b>	<b>4</b>
<b><u>1.1. General remarks</u></b>	<b>4</b>
<b><u>1.2. Customer satisfaction</u></b>	<b>4</b>
<b><u>1.3. Customer response</u></b>	<b>4</b>
<b><u>2. Hardware description</u></b>	<b>6</b>
<b><u>2.1. Technical data</u></b>	<b>7</b>
<b><u>2.2. 3pin connection cable</u></b>	<b>8</b>
<b><u>2.3. LED's</u></b>	<b>8</b>
<b><u>3. Software</u></b>	<b>10</b>
<b><u>3.1. "VCP Driver (Virtual COM-Port)" Installation</u></b>	<b>10</b>
<b><u>4. Appendix</u></b>	<b>13</b>
<b><u>4.1. Product information</u></b>	<b>13</b>
<b><u>4.2. Revisions</u></b>	<b>14</b>
<b><u>4.3. Copyrights and trademarks</u></b>	<b>15</b>



# Introduction

---



# 1. Introduction

## 1.1. General remarks

First of all, we would like to congratulate you to the purchase of a high quality DEDITEC product.

Our products are being developed by our engineers according to quality requirements of high standard. Already during design and development we take care that our products have -besides quality- a long availability and an optimal flexibility.

### **Modular design**

The modular design of our products reduces the time and the cost of development. Therefore we can offer you high quality products at a competitive price.

### **Availability**

Because of the modular design of our products, we have to redesign only a module instead of the whole product, in case a specific component is no longer available.

## 1.2. Customer satisfaction

Our philosophy: a content customer will come again. Therefore customer satisfaction is in first place for us.

If by any chance, you are not content with the performance of our product, please contact us by phone or mail immediately.

We take care of the problem.

## 1.3. Customer response

Our best products are co-developments together with our customers. Therefore we are thankful for comments and suggestions.

# Hardware description

---

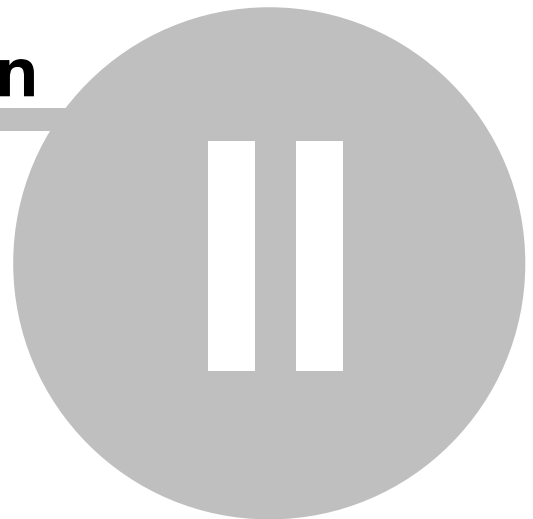

## 2. Hardware description

This USB to RS-232 converter (TTL-Level) is suitable for e.g. debugging on microcontroller circuits. Also your processor board will be protected by **galvanic isolation**.

This little USB-Stick transmits serial data with TTL-Level (e.g. debugging informations) on the USB port. Normally there are only TTL-Signals available on serial ports by processors. With this tool these signals can be comfortably displayed on your PC or notebook. The “sensitive TTL-Signals” will be savely connected by galvanic isolation to a PC.

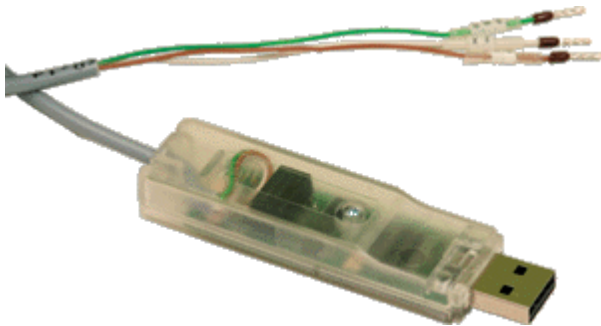

## 2.1. Technical data

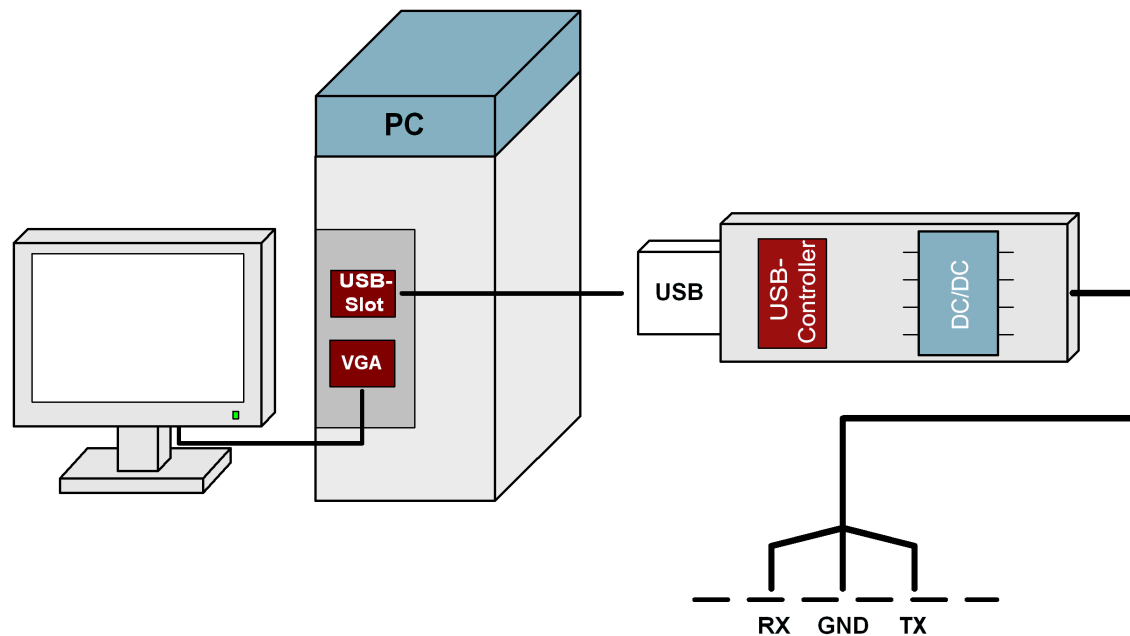

- +5V power supply (USB-BUS)
- USB to RS-232 (TTL-Level)
- A LED for TX and RX
- Galvanically isolated
- 50 Baud ..3MBaud (configurable per software)
- Windows VCP (Virtual COM Port)
- Linux Driver inclusive
- Dimensions: 84,5 x 21 x 12,5/9,5 mm (without cable)

## 2.2. 3pin connection cable

The connection to the stick on the RS-232 side will be made by a 3pin connection cable. The ends of the wires are labeled with "RX", "TX" and "GND".

### RS-232 Pin Assignment

Pin	
Brown	RX
White	TX
Green	GND

## 2.3. LED's

Two LED's visualisation of transmit and receivedata.

1\*TX (transmit)

1\*RX (receive)

# Software



## 3. Software

### 3.1. “VCP Driver (Virtual COM-Port)” Installation



Insert the DEDITEC driver CD in your CD drive and start “**vcp\_driver\_install.exe**”. The “**VCP driver (Virtual COM-Port)**” software is also available at <http://www.deditec.de/en/entwicklungstools/download.html>.

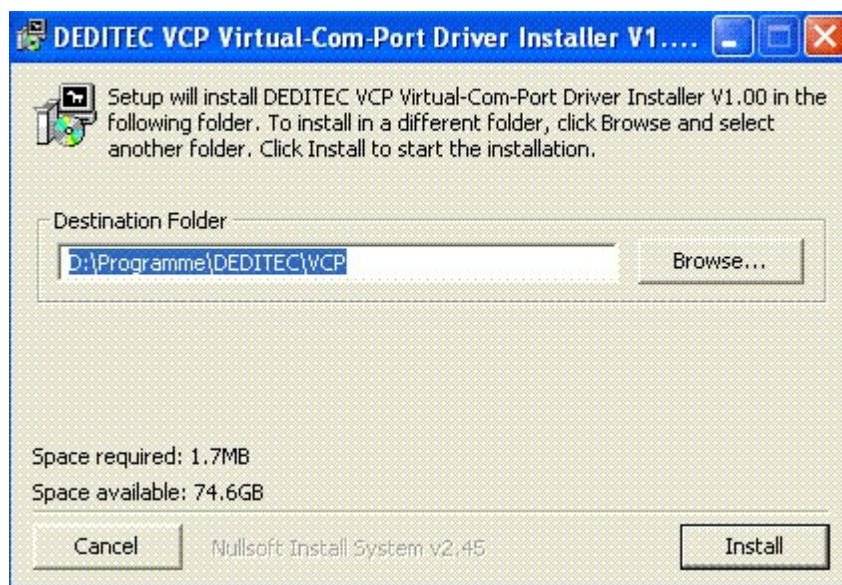

Press “**Install**”.

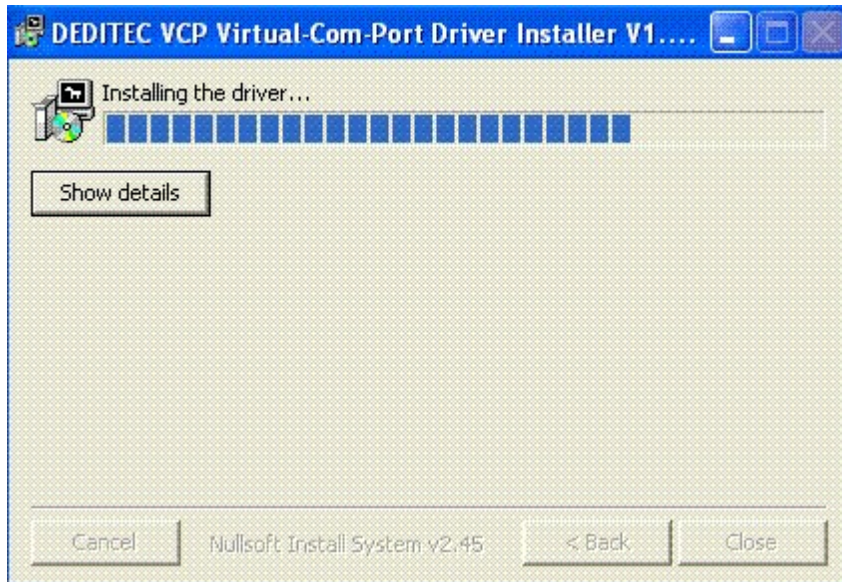

The driver will be installed.

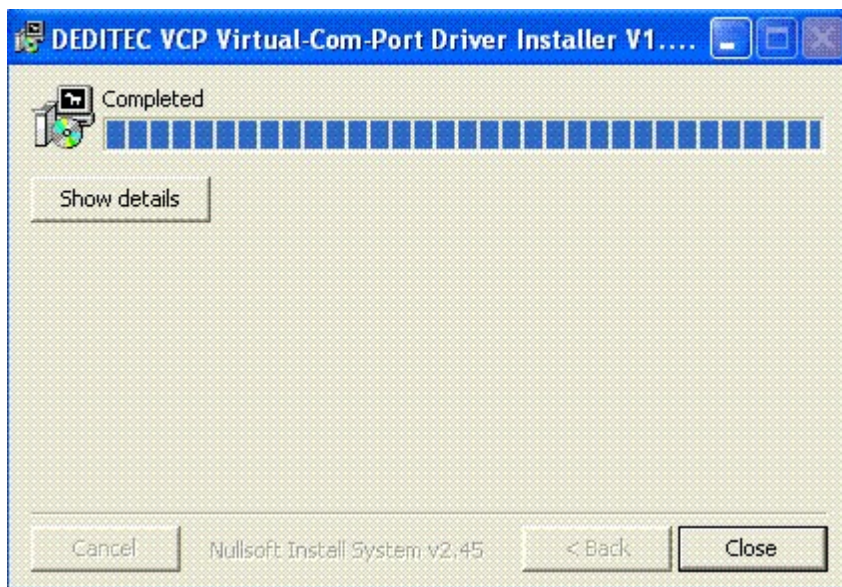

The **“VCP Driver (Virtual COM-Port)”** Software has been installed now. Press **“Close”** to finish installation.

# Appendix

IV

## 4. Appendix

### 4.1. Product information

Ord.no.: USB-RS232-TTL-STICK

Product: USB-RS-232 (TTL-Level)-converter for the connection to serial ports (TTL-Level) to PC by USB

Productlink: <http://www.deditec.de/en/entwicklungstools/prod/usb-rs232-ttl-stick.html>

## 4.2. Revisions

Rev 1.00	First issue
Rev 2.00	Design change

### **4.3. Copyrights and trademarks**

Linux is registered trade-mark of Linus Torvalds.

Windows CE is registered trade-mark of Microsoft Corporation.

USB is registered trade-mark of USB Implementers Forum Inc.

LabVIEW is registered trade-mark of National Instruments.

Intel is registered trade-mark of Intel Corporation

AMD is registered trade-mark of Advanced Micro Devices, Inc.